

# SONIC ROTARY ARM

*experience superior film economy*

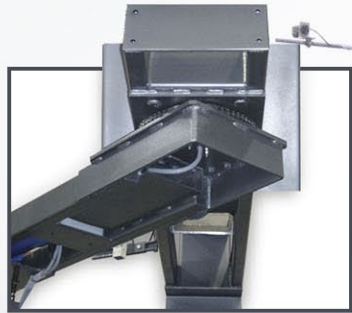

## SEMI-AUTOMATIC ROTARY ARM

The X-STRETCH pre-stretch film carriage provides superior film economy, film tension and user safety

- ✓ Uses 20" machine film
- ✓ Electronically adjustable film tension
- ✓ 250% film pre-stretch ratio, others available
- ✓ Maintenance free ball bearing carriage guide
- ✓ Automatic corner compensation
- ✓ Lifetime warranty on stretch rollers

The Sonic RTX features an all steel robust frame and the rotary arm ring gear support requires very little maintenance

- ✓ Structural steel frame
- ✓ Lag down pole stand
- ✓ Easy access to components
- ✓ 1/2 HP turntable drive motor
- ✓ Heavy duty arm tower chain drive
- ✓ Heavy duty ring bearing arm support support casters

The versatile HMI touch screen allows for a quick setup to wrap various type pallet loads

- ✓ Photo-eye automatic height detection
- ✓ Separate top and bottom wrap count 1-10
- ✓ Rotary tower soft start/stop
- ✓ Dual adjustable film carriage speed
- ✓ Lockable wrap parameters access
- ✓ Safety photo-eye in front of rotary tower
- ✓ Automatic rotary tower home position

### POPULAR OPTIONS

- Wrap height extension for taller pallets
- Platform scale with digital weight indicator
- 30" film carriage
- Safety guarding around wrap zone
- Auto film cut
- Arm speed increase

### TECHNICAL SPECIFICATIONS

➤ Arm Speed	Adjustable up to 14 RPM
➤ Control Type	Full-Feature Semi-Automatic
➤ Max. Load Height	84"
➤ Max. Load Diameter	76"
➤ Pre-Stretch Ratio	250% standard
➤ Max. Load Size	54" x 54"
➤ Electrical	115/1/60 15amp
➤ Warranty	3/5 year limited

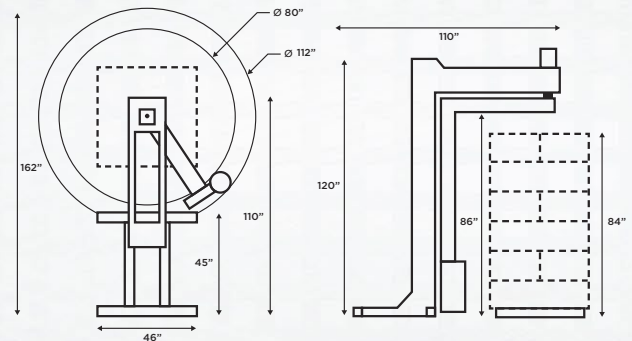

SONIC RTX

# Machi

3245Bd. Pitfield, Saint-Laurent, QC Canada H4S 1H3

info@strapco.ca [www.strapco.ca](http://www.strapco.ca)

514 683 0555

514 683 0557

Strapco