

SONIC ROTARY ARM

experience superior film economy



SEMI-AUTOMATIC ROTARY ARM

POPULAR OPTIONS

- > Wrap height extension for taller pallets
- > Platform scale with digital weight indicator
- > 30" film carriage
- > Safety guarding around wrap zone
- > Auto film cut
- > Arm speed increase

TECHNICAL SPECIFICATIONS

> Arm Speed	Adjustable up to 16 RPM
> Control Type	Full-Feature Semi-Automatic
> Max. Load Height	84"
> Max. Load Diameter	76"
> Pre-Stretch Ratio	250% standard
> Max. Load Size	54" x 54"
> Electrical	115/1/60 15amp
> Warranty	3/5 year limited

The X-STRETCH pre-stretch film carriage provides superior film economy, film tension and user safety

- ✓ Uses 20" machine film
- ✓ Electronically adjustable film tension
- ✓ 250% film pre-stretch ratio, others available
- ✓ Maintenance free ball bearing carriage guide
- ✓ Automatic corner compensation
- ✓ Lifetime warranty on stretch rollers

The Sonic RTG features an all steel robust frame and the rotary arm ring gear support requires very little maintenance

- ✓ Structural steel frame
- ✓ Gantry frame
- ✓ Easy access to components
- ✓ 1/2 HP turntable drive motor
- ✓ Heavy duty arm tower chain drive
- ✓ Heavy duty ring bearing arm support support casters

The versatile HMI touch screen allows for a quick setup to wrap various type pallet loads

- ✓ Photo-eye automatic height detection
- ✓ Separate top and bottom wrap count 1-10
- ✓ Rotary tower soft start/stop
- ✓ Dual adjustable film carriage speed
- ✓ Lockable wrap parameters acces
- ✓ Safety photo-eye in front of rotary tower
- ✓ Automatic rotary tower home position

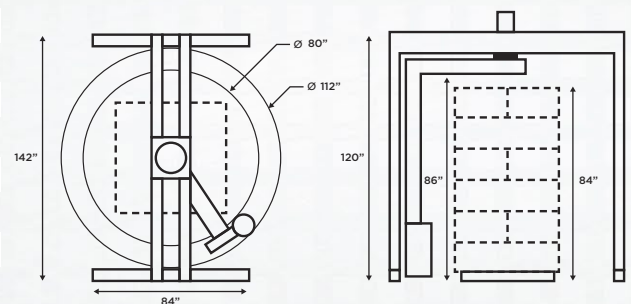

SONIC RTG

Machi

📍 3245Bd. Pitfield, Saint-Laurent, QC Canada H4S 1H3

✉ info@strapco.ca www.strapco.ca

📞 514 683 0555

📠 514 683 0557

🏢 Strapco