

ROCKET LINE

the ideal solution for low volume pallet wrapping

FOOTSWITCH ACTIVATED TURNTABLES

ROCKET L ▶

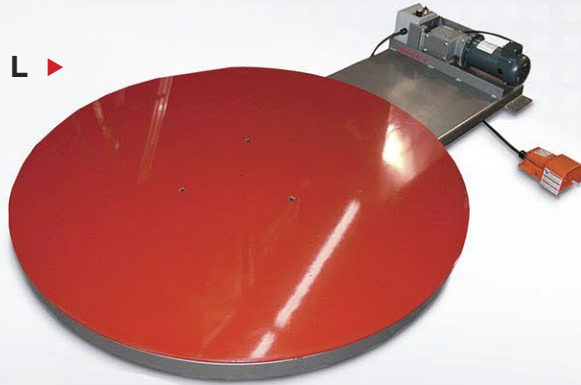

ROCKET H ▼



The unique PRO-GLIDE support casters are robust and require very little maintenance.

- ✓ Structural steel frame
- ✓ Forklift portable
- ✓ Very low maintenance turntable drive
- ✓ Easy access to components
- ✓ 1/2 HP turntable drive motor
- ✓ Heavy duty turntable chain drive
- ✓ Heavy duty turntable support casters
- ✓ Turntable soft start/stop
- ✓ Rugged all steel footswitch

The operator can easily set the turntable rotating speed to rapidly wrap any type of pallet.

TECHNICAL SPECIFICATIONS

▶ Turntable Speed	Adjustable up to 14 RPM
▶ Control Type	Footswitch activated
▶ Max. Load Capacity	5,000 lbs
▶ Max. Load Height	Unlimited
▶ Turntable Size H	48" x 48" diameter octagonal
▶ Max. Load Size H	Unlimited
▶ Turntable Height H	9" from floor
▶ Turntable Size L	59" diameter
▶ Max. Load Size L	54" x 54"
▶ Turntable Height L	3" from floor
▶ Electrical	115/1/60 10 amp
▶ Warranty	1 year limited

POPULAR OPTIONS

- ▶ Loading ramp for pallet jack use for L
- ▶ Surround deck for pit mounting for L
- ▶ Frame extension for larger pallets for L
- ▶ Turntable weight capacity increase
- ▶ Scale package with digital weight indicator
- ▶ 59" diameter round turntable for H

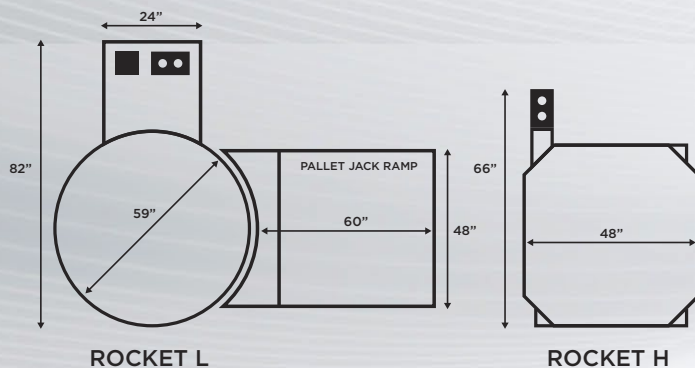

Mach 1

3245 Bd. Pitfield
Saint-Laurent, QC
Canada H4S 1H3

514 683 0555

514 683 0557

info@strapco.ca

www.strapco.ca

Strapco