

TRC-6 SoniXs

REVOLUTIONIZE YOUR
END-OF-LINE [PACKAGING]
PERFORMANCE



Fully Automatic Strapping Machine



Standard 6 SoniXs® Ultrasonic Sealer



Track Size Up To 2600mm Wide



Up To 30 Bundles Per Minute



Machine Options Available

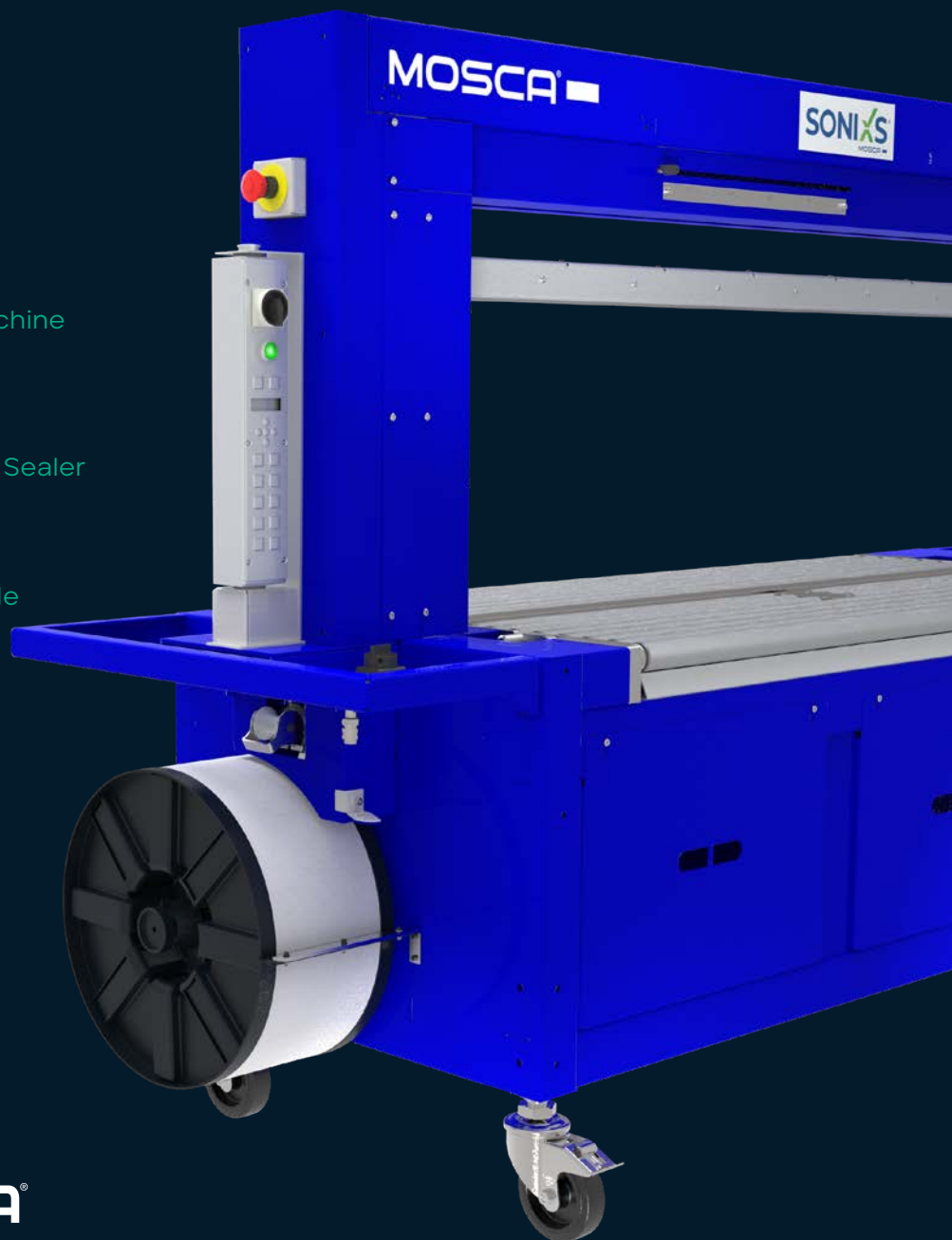

TRC-6 SoniXs

FULLY AUTOMATIC STRAPPING MACHINE FOR CORRUGATED BUNDLES

The TRC6-SoniXs® strapping system offers a rugged roller bed transport system with SoniXs® sealing technology for maximum uptime, reliability, and performance. Features include toolless strap head disassembly and lift-out conveyors for easy and convenient routine maintenance. Its variable speed conveyor, dual press, and rotating operator panel make the TRC6-SoniXs® an ideal choice for corrugated bundle applications.



The Ultimate Strap Sealing Solution

Mosca's proprietary SoniXs® ultrasonic sealing heads have revolutionized strapping systems offering significant and proven advantages over traditional heat-seal technologies, including cost, maintenance, and longevity across all industries and applications.

Unlike heat seal systems, SoniXs® strap seals are made without the use of high-temperature components, reducing energy costs, improving safety, and generating lower emissions.

A SoniXs® seal is harder to break, and the visible evidence of a break is irreversible. The distinctive impression on Mosca's ultrasonically-sealed strap makes it easy to identify if the packaging has been tampered with. The seal will be distinguishably different if a strap is removed and reapplied.

Key Benefits

- + **INCREASED SEAL STRENGTH**
 - + **COST SAVINGS**
 - + **LASTING DURABILITY**
 - + **CONSISTENT SEALING**
 - + **WORRY-FREE PRODUCT SECUREMENT**
 - + **ENERGY CONSERVATION**
 - + **LOW MAINTENANCE**
 - + **SEALS BOTH PP AND PET**
-

TECHNICAL SPECIFICATIONS

Production Rate

Up to 30 bundles per minute

Track Size

Standard Widths: 1650mm (65"), 1250mm (49")
Other widths available: 1000mm (39"), 2200mm (86.5")
2600mm (102")
Height: 466mm (18") with press 590mm (23") without press

Electrical

200 - 575V 50/60 Hz, 1.3 kVA, 3 Ph.

Air Requirements

4 CFM @ 87 PSI

Conveyor

Extruded splined roller conveyor bed. Easy toolless removal.

Conveyor Speed

Variable 30 - 180 FPM

Conveyor Height

Outriggers Required: 25.5" - 30.5" (648mm - 775mm)
Standard: 30.5" - 39.5" (775mm - 1004mm)
1 Riser required: 39.5" - 47" (1004mm - 1194mm)
2 Risers + Outriggers required: 47" - 54" (1194mm - 1371.5mm)
3 Risers + Outriggers required: 54" - 61.5" (1372mm - 1562mm)

Strapping

Standard: 5mm Polypropylene (PP) Other strap sizes available on request

Strap Tension

Infinitely adjustable from 10 - 60 Lbs.

Strap Seal

Standard: SoniXs® ultrasonic seal

Seal Location

Center Bottom Seal

Machine Shipping Weight

Approx. 1650 Lbs. (depending on model)

Casters

Four Swivel-Lock Casters

OPTIONS

- + Dual dispenser
- + Light tower
- + Small bundle transport
- + Back stop
- + Protective guarding
- + Small bundle option
- + Automatic coil changer
- + Floor troughs
- + Under table lighting
- + Automatic blow out
- + Reverse flow (left to right)
- + Custom paint color (RAL color chart)
- + More options available

SCAN
HERE



Want to see the TRC-6 SoniXs® in action? Use the QR code to learn more.

MACHINE DIMENSIONS

		MACHINE ARCH SIZE									
		1000 x 600		1250 x 600		1650 x 600		2200 x 600		2600 x 600	
		Inches	mm	Inches	mm	Inches	mm	Inches	mm	Inches	mm
A		18	460	18	460	18	460	18	460	18	460
B		39.4	1000	49	1250	65	1650	86.6	2200	102.3	2600
C	Outrigger Height	25.5-30.5	648-772	25.5-30.5	648-772	25.5-30.5	648-772	25.5-30.5	648-772	25.5-30.5	648-772
	Standard Height	30.5-39.5	775-1001	30.5-39.5	775-1001	30.5-39.5	775-1001	30.5-39.5	775-1001	30.5-39.5	775-1001
	+1 Riser Height	39.5-47	1003-1194	39.5-47	1003-1194	39.5-47	1003-1194	39.5-47	1003-1194	39.5-47	1003-1194
D	+2 Riser + Outriggers Height	47-54	1196-1372	47-54	1196-1372	47-54	1196-1372	47-54	1196-1372	47-54	1196-1372
	+3 Risers + Outriggers Height	54-61.5	1374-1562	54-61.5	1374-1562	54-61.5	1374-1562	54-61.5	1374-1562	54-61.5	1374-1562
E		86	2188	86	2188	102	2588	123.5	3138	139	3538

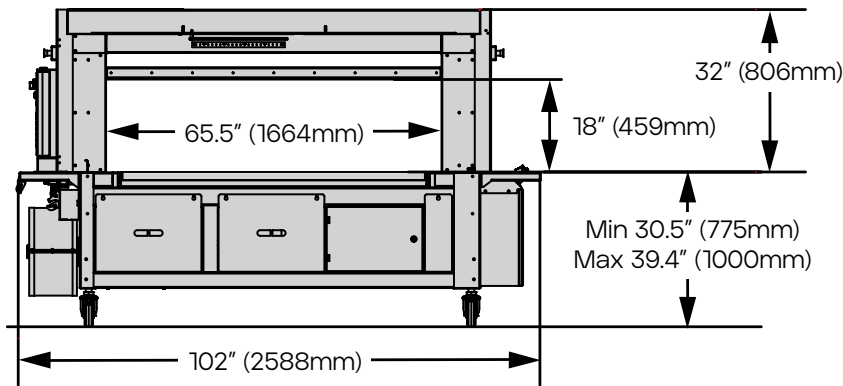

Shown: TRC-6-1650 with Standard Conveyor Height

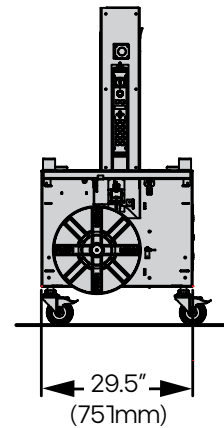

CONTACT US FOR A FREE CONSULTATION TODAY
www.eamosca.com | info@eammosca.com

U.S.A., Latin America & The Caribbean

EAM-Mosca Corporation
 675 Jaycee Drive, Hazle Township, PA 18202
 Phone: 800.456.3420 / 570.459.3426
 Fax: 570.455.2442

Canada

EAM-Mosca Canada Ltd.
 170 William Smith Drive, Whitby, Ontario, L1N 9N3
 Phone: 800.633.6392 / 905.665.8225
 Fax: 905.665.8188