



EoL

END OF LINE

DEKKA 500 FULLY AUTOMATIC CASE ERECTOR



Perfect for light manufacturers operating a low-speed automated packaging line

The DEKKA 500 is a heavy duty fully automatic case erector developed for the entry level market. This compact machine is ideal for customers looking to upgrade to automatic machinery with a tight budget and limited floor space. The DEKKA 500 is able to reach speeds of up to 10 cases per minute, perfect for light manufacturers operating a low-speed automated packaging line. It also features a full color touchscreen HMI, operator friendly color coded change handles and pictorial guides and is also optimized for the high performance Dekka tape head, ensuring an effective and reliable case seal.

FEATURES AND BENEFITS

- Entry level automatic case former ideal for applications looking to upgrade from semi-automatic machinery
- WISE System of controls for easy machine operation, on-board machine maintenance and troubleshooting
- Small machine footprint for applications with minimal floor space
- Quick and easy size change with on machine pictorial guides and color coded size change handles
- Deepest service support network across all of North America

DEKKA 500 FULLY AUTOMATIC CASE ERECTOR

SPECIFICATIONS

Weight	980 lbs / 445 kg
Machine Dimensions	83"(L) x 73"(W) x 86" (H)
Air	10 cubic feet per cycle at 90psi
Electrical	120Volts, 1PH, 60 Hz - 8 amps
Speed	Up to 10 cases per minute

CASE SIZE RANGE

	Length	Width	Height
Minimum	10" 254mm	5" 127mm	8" 203mm
Maximum	22" 558mm	16" 406mm	18" 457mm
Discharge Height	24" - 29"		

*Discharge height must be specified at the time of order

CONFIGURATION

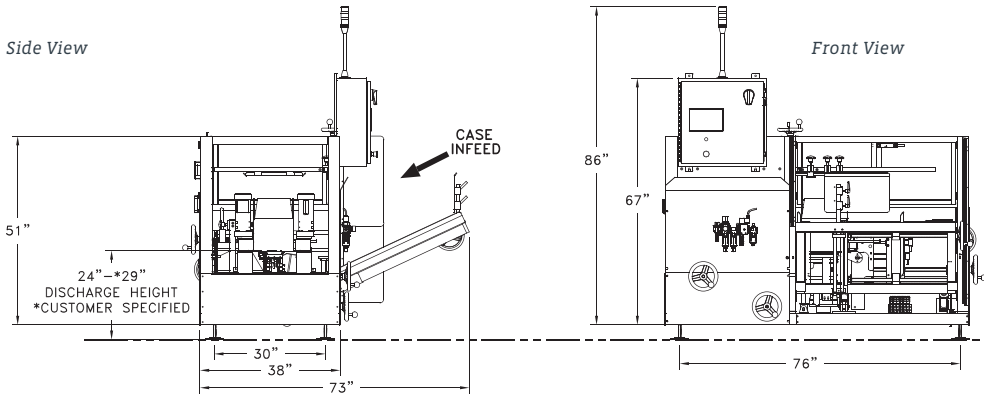

OPTIONS AND ACCESSORIES

- Tape management
- Digital dial indicators
- Auxiliary E-stop
- Dekka 3" tape head
- Caster wheels

FEATURES



Developed and constructed with heavy duty components for long lasting performance



Full color 7" HMI touchscreen for easy and intuitive machine operation



Compact design allows machine to fit in small operations

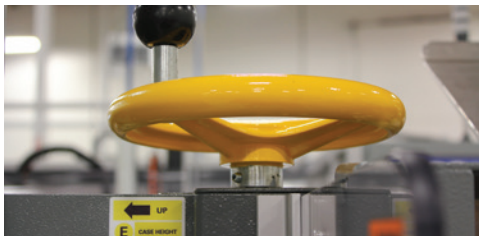

Color-coded size change labels and minimal amount of change points allow for quick and easy size changes

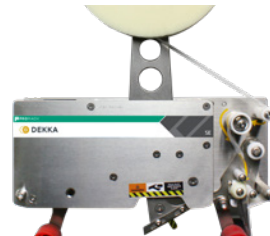

Reliable case sealing with the industry leading high performance Dekka tape head

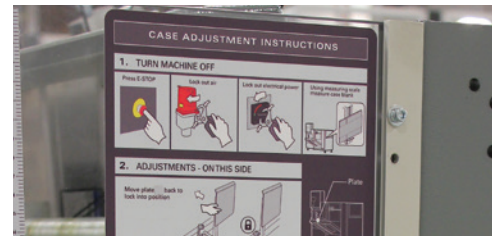

User friendly pictorial guides allow for easy training and operation

©2019 ProMach Inc. ProMach reserves the right to change or discontinue specifications and designs shown in this brochure without notice or recourse
PM-DEK-SP101_Dekka_Dekka 500. Last revised 11/06/19.

PHONE
604-930-9300

FAX
604-270-7897

EMAIL
Dekka@ProMachBuilt.com

WEB
Dekkaindustries.com

13471 Vulcan Way,
Richmond, BC Canada V6V 1K4